

# KROMOQUARTZ<sup>®</sup> TRZ (TERRAZZO)

## Series 5000

PAGE 1 of 4

### PRODUCT DESCRIPTION:

**KROMOQUARTZ TRZ** is a protective and decorative, three-dimensional flooring system formulated by blending 100% solids semi tinted epoxy liquids with specially graded, natural quartz silica aggregates. This achieves the natural look of Terrazzo.

**KROMOQUARTZ TRZ** is trowel-applied at 3/16" (4.5mm) to 1/4" (6mm) thickness and sealed with clear epoxy to provide superior protection in institutional, commercial and industrial environments.

### PRODUCT FEATURES:

- Versatile, **KROMOQUARTZ TRZ**'s rich TERRAZZO like appearance can be customized to almost any taste or design requirement.
- Durable and rugged.
- Application by factory-approved contractors ensures guaranteed top quality installations.
- Seamless, monolithic and sanitary - impervious to spillage of water, oil, grease and most chemicals. Does not support bacteria or fungi growth.
- 100% solids epoxy formulation means this is an odourless product formulated without solvents thus reducing health and safety concerns.
- Slip-resistant textures available for added safety in wet areas.
- Available with integral coved bases, which aid in housekeeping.
- Zinc strips can be incorporated in the floor to divide colours and create endless design options.
- Optional satin finish.

- Trowel liquid can be tinted to endless variety of colours.
- Can achieve the natural look of concrete.

### TYPICAL USES:

- Overlayment for concrete floors in light, medium and heavy-duty industrial environments.
- Sanitary environments subjected to constant cleaning. (i.e. laboratories, hospital rooms, pharmaceutical plants, washrooms, commercial kitchens, institutional facilities, airports.)
- Repair of deteriorated and worn concrete floors.
- Showrooms and retail outlets.

### PERFORMANCE DATA

Typical Performance After 7 Days Cure @25°C(77°F)

<b>COMPRESSIVE STRENGTH</b>	10,370 PSI (ASTM 695-85)
<b>TENSILE STRENGTH</b>	2,000 PSI (ASTM C-307)
<b>FLEXURAL STRENGTH</b>	5,000 PSI (ASTM C-580)
<b>HARDNESS</b>	85 (SHORE D)
<b>ABRASION RESISTANCE</b>	.033g (ASTM D4060-90)
<b>MAR RESISTANCE</b>	1.0Kg (ASTM D5178-91)
<b>BOND STRENGTH</b>	100% CONCRETE FAILURE

# KROMOQUARTZ<sup>®</sup> TRZ (TERRAZZO)

## Series 5000

PAGE 2 of 4

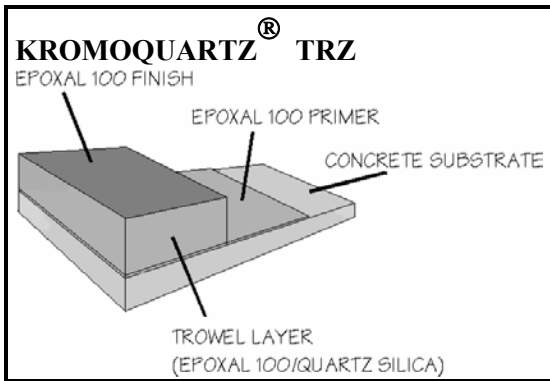

## SURFACE PREPARATION:

### New Concrete Preparation:

All surfaces to be coated must be clean, dry and free of all contaminants. New concrete must be cured a minimum of 28 days with no more than 3% moisture content. Any curing or hardening compounds, form oils, release agents or laitance must be removed by means of mechanical abrasion. Shot blasting or diamond grinding are the recommended methods. These two means of mechanical abrasion will clean the surface and open the pores of the concrete to allow maximum penetration of the primer. Ensure the methods of mechanical abrasion are dust-free.

### Existing Concrete Preparation:

Ensure all loose concrete is removed, using a scarifier, diamond grinder, bush hammer or other methods. Remove any contamination, including grease and oil using an industrial cleaner. (Consult your NPC representative for recommended cleaners) Prepare the entire floor by method of a shot blaster, or diamond grinder. Patch any uneven or damaged concrete using

“NPC Epoxal 100 Patch” or consult your NPC representative for further instruction.

Existing coated surfaces must be intact and tightly bonded to substrate below. If stability of existing coating is in question, test a small section and check for lifting. Hard or glossy surfaces must be abraded to improve adhesion performance. *NPC will not warrant the application of Epoxal coatings over an existing paint or urethane.*

### Wood Preparation:

All wood surfaces to be coated must be clean, dry and free of all contaminants. The wood surface must be very rigid, with no possible movement. Fill any voids, or seams with NPC “Epoxal 100 Patch.”

## INSTALLATION TOOLS:

- Epoxy Jiffy Mixer(Drill and Mixing Bit)
- Two-5 gallon Mortar Mixers
- 3”x12” Steel Trowel

## PRIMING:

**KROMOQUARTZ TRZ** requires a primer to be applied prior to the mortar layer. In most cases, Epoxal 100WH serves as an excellent primer. If a low viscosity primer is required, use Epoxal 100 Primer. The recommended thickness of the primer for **KROMOQUARTZ TRZ** is 8mils. Mix primer as detailed in Epoxal 100WH Product Information. If the concrete substrate has recently been subjected to moisture, we recommend Epoxal 100 DCP. *(Please consult your NPC representative for further details about Epoxal 100 DCP.)*

### MIXING:

The mortar layer of **KROMOQUARTZ<sup>®</sup> TRZ** is comprised tinted of Epoxal 100WH and finely graded silica aggregates. The epoxy liquid content needed for 35lbs. of natural silica is 2.4L. In a 1 gallon measuring pail, add 0.8L of Part B(Catalyst) into 1.6L of Part A(Resin). Mix with a jiffy mixer for one minute. Pour mixed liquids into the 5 Gal pail mixer, and begin mixing. Add the graded silica aggregates immediately and mix for one minute. When one minute is up, immediately pour the contents of the mixing pail out on the floor. Repeat this process for all additional mixes.

### APPLICATION:

**KROMOQUARTZ<sup>®</sup> TRZ is a hand-toweled finish.**

- Step 1.* After the floor has been properly prepared to accept coating, apply one coat of primer to the entire area at a spread rate of 8 mils. If the application of the mortar layer is not going to be applied immediately, broadcast silica #16 into the wet primer. This will allow the mortar layer to bond very well to the primer if it cures.
- Step 2.* Mix the mortar layer according to instructions, and pour contents of the mixing pail on the floor.
- Step 3.* Using a steel trowel, screed the material to a uniform thickness. Compact the material to form a tight even surface.

*Step 4.* If an integral cove base is required, glue a zinc cove strip at the specified height to every vertical surface in the area to receive

**KROMOQUARTZ<sup>®</sup> TRZ.**

Using a cove trowel, incorporate the base into the floor. Be sure not to leave ridges or lines on the cove base or the floor. They cannot be removed afterward.

*Step 5.* Clean your trowel often to remove the resin build-up. If the resin build-up is blended into the floor, it will discolour the finish. Clean your trowel by wiping it with NPC "Trowel Thinner." This will make working with the mortar easier and prevent discolouration. Check the thickness of the material at frequent intervals and ensure a level, smooth surface is produced.

*Step 6.* Once you are finished troweling the entire surface, allow the mortar to cure.

*Step 7.* Mix Epoxal 100WH and apply as per Epoxal 100WH Application instructions. This first coat over the mortar is referred to as a grout coat. Apply the grout coat at whatever spread rate is needed to fill any imperfections and create a sealed surface. This coat is usually 6-8 mils in thickness.

*Step 8.* Apply the topcoat to the surface within 24 hours after the grout coat is completed. The topcoat should be applied at a thickness of 10-12 mils.

*Step 9.* To achieve a textured finish, a third coat can be applied. Spread the mixed material at a thickness of 5-6

mils with a rubber squeegee and back roll with a saturated medium nap roller. Using a hopper blower, broadcast a small amount of graded silica sand over the entire floor. Silica 530 will create a medium texture that is non-slip, and relatively easy to clean. Back roll the coating immediately to encapsulate the sand and achieve a uniform textured surface.

**Step 10.** If a satin finish is required, apply two coats of 2K Acrylic Urethane W.B. Satin. Refer to 2K Acrylic Urethane W.B. for installation instructions.

**Note: Epoxal 100WH is the epoxy liquid most commonly used in this system, as a primer, tinted trowel liquid, grout coat and topcoat. There are other products that can be used as well. Epoxal 100 Primer and Epoxal 100DCP both make excellent primers. Epoxal 100TL is a low viscosity binder, while Epoxal 100FC is a quick curing resin that can also be used as a trowel binder. Epoxal 100FC, Epoxal 100CR and Epoxal 100CC are all quality alternatives to substitute in place of Epoxal 100WH as a topcoat or trowel binder material.**

### LIMITATIONS:

- This product must be applied to a substrate with a minimum temperature of 16<sup>0</sup>C(61<sup>0</sup>F).
- This product will amber if it is under prolonged ultra violet light.
- This product is not recommended for areas that are exposed to severe thermal shock.
- Working time and cure times are very dependant on temperature.
- Maintain a constant temperature before and during application period, and until coating is cured.

### CURING:

At a temperature of 22<sup>0</sup>C(72<sup>0</sup>F), Epoxal 100WH will be tack free within 10-12 hours. It will support light traffic at 24 hours and will reach full cure and chemical resistance in 7 days.